

# TITANIUM ANODE AND POTENTIAL CONTROLLER PS

MODEL: TH-Ti800

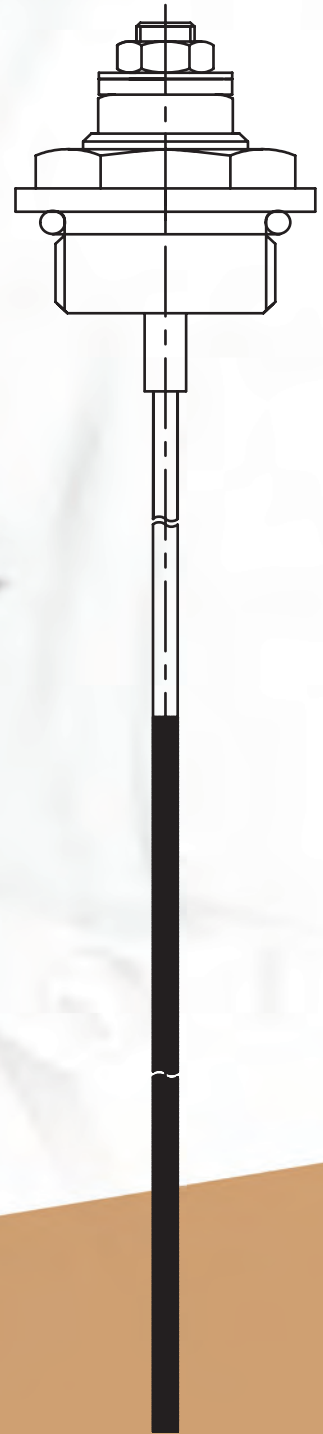

TITANIUM ANODE AND POTENTIAL CONTROLLER PS  
FOR STAINLESS STEEL TANKS **TH-Ti800**



Our primary goal is to ensure our customer's satisfaction, which is why we introduce devices to the market made from components of renowned global manufacturers and materials that guarantee long and trouble-free operation. From the beginning of our company's activities, we have attached great importance to the appearance of our products.

We believe that devices such as heat pumps, hydraulic cabinet assemblies, or even just domestic hot water tanks should be an integral part of good design. Meeting these expectations, our devices blend perfectly with the dream homes and offices of our customers.

We place a strong emphasis on usability, quality of craftsmanship, and product durability, ensuring that we deliver devices prepared for years of trouble-free and efficient operation.

## TABLE OF CONTENTS

1. SAFETY SYMBOLS .....	4
2. RULES FOR SAFE INSTALLATION AND USE .....	5
3. DESCRIPTION AND APPLICATION .....	5
4. SELECTION TABLE FOR TITANIUM ANODE .....	5
5. TECHNICAL SPECIFICATIONS .....	6
5.1 POTENTIAL CONTROL PS .....	6
5.2 TITANIUM ANODE .....	7
6. INSTALLATION OF TITANIUM ANODE AND POTENTIAL CONTROL PS ...	8
7. USAGE .....	9
8. INSPECTION .....	9
9. DISPOSAL .....	9
10. SERVICE .....	9









# IMPORTANT!

- This Installation and User Manual contains essential information regarding the safe use, correct installation, and operation of the titanium anode and potential control PS in stainless steel tanks.
- Before use, carefully read and understand this manual.
- Keep the Installation and User Manual for future reference.
- Pass the manual on to any subsequent owner or user of the titanium anode and potential control PS.
- During the use of the titanium anode and potential control PS, follow applicable safety regulations and guidelines.
- Due to the rapid development of our products, the contents of this manual may change without notice.

## 1. SAFETY SYMBOLS

Safety symbols and warning signs presented below are used to emphasize particularly important safety information and principles for the correct use of the titanium anode and potential control PS:

SYMBOL	MEANING
 DANGER	<b>Immediate danger!</b> Failure to comply may result in death or serious bodily injury.
 WARNING	<b>Possible danger!</b> Failure to comply may result in death or serious bodily injury.
 CAUTION	<b>Dangerous situation!</b> Failure to comply may result in minor or moderate bodily injury or property damage.
	<b>Read the manual.</b>
	<b>Warning of electric shock.</b>
	<b>Caution hot surface!</b>

## 2. RULES FOR SAFE INSTALLATION AND USE

During the safe installation and use of the titanium anode and potential control PS, you should:

- Use the titanium anode and potential control PS only in a technically sound condition and in accordance with its intended purpose.
- Entrust the installation, start-up, and disassembly only to properly trained personnel.
- Do not disassemble the titanium anode under pressure.
- Do not make any modifications to the titanium anode and potential control PS that are not specified in the instructions.
- Make connections according to the markings provided in the instructions.

## 3. DESCRIPTION AND APPLICATION

Water heaters in single-family homes are used to heat, store, and supply hot water at a specified temperature. Over time, a natural occurrence is corrosion. In hot water tanks, electrochemical corrosion occurs, characterized by the formation of corrosive cells. To extend the life of the tank, additional cathodic protection should be applied, which involves installing a titanium anode inside the tank, connected to an external power source. The tank's surface becomes the cathode, where reduction reactions occur, reducing the degree of oxidation of the depolarizer, rather than oxidizing the metal.

Titanium anodes are used to protect against corrosion in domestic hot water tanks, and the basis of this technology is protection against corrosion by the current supplied from the potential control PS controller. Unlike a consumable magnesium anode, the current titanium anode works with almost no mass loss due to being made entirely of titanium and coated with an insoluble layer of rare earth metal oxides. It is also powered from an external source, and the protective potential is closely controlled by electronic equipment. Since the anode practically does not dissolve in water, it only needs to be replaced every 10 years or so, ensuring proper tank protection. An additional advantage is the elimination of the smell of hydrogen sulfide, which is often associated with magnesium anodes.

## 4. SELECTION TABLE FOR TITANIUM ANODE

Below is a table for selecting a titanium anode for stainless steel tanks:

DEVICE TYPE	TANK CAPACITY IN [liters]	ANODE PLUG THREAD [inches]
TH-Ti800	200 to 500	R3/4

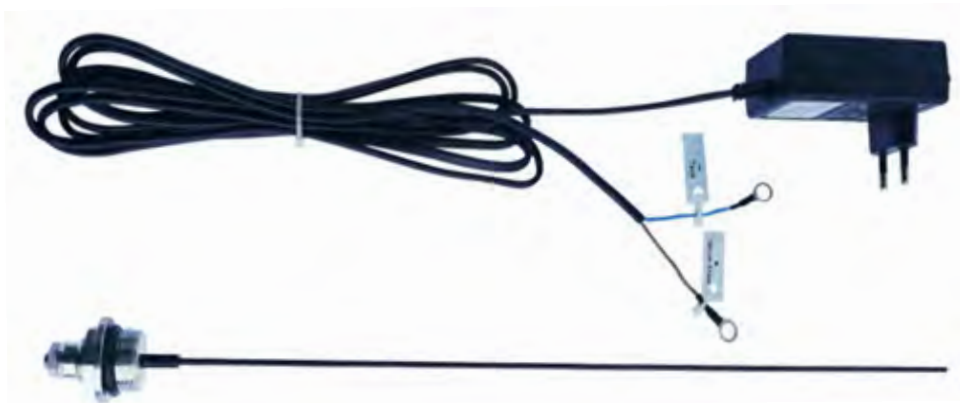

## 5. TECHNICAL SPECIFICATIONS

### 5.1. POTENTIAL CONTROL PS

PARAMETERS	DESCRIPTION
AC Supply	110-240V
AC Network Frequency	50-60Hz
Maximum AC Current Draw	0,03 A
Maximum DC Power Supply	10V
Maximum DC Current Draw	100 mA
Ambient Temperature	0-70°C
Protection Degree	IP20

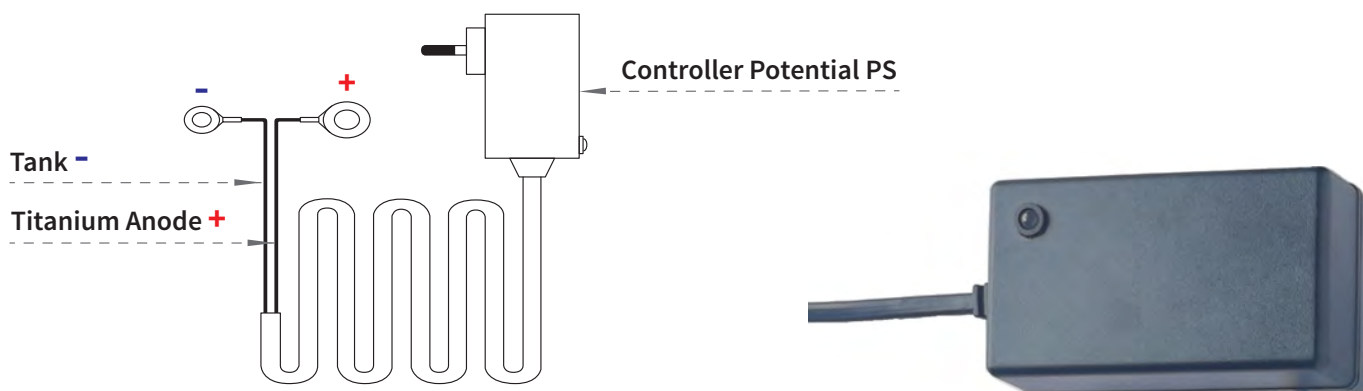

The Controller Potential PS is an external power supply rated at 230V~ / 10V=, which is powered from a 230V~ AC mains supply. On the DC side, it has two wires terminated with eyelet terminals labeled as "+" and "-". The controller is equipped with a status LED on its housing, which indicates the current operating status of the controller. The wire with the "+" labeled terminal should be connected to the terminal screw on the titanium anode plug, while the wire with the "-" labeled terminal should be connected to the terminal screw on the tank (see the connection example in the diagram below).

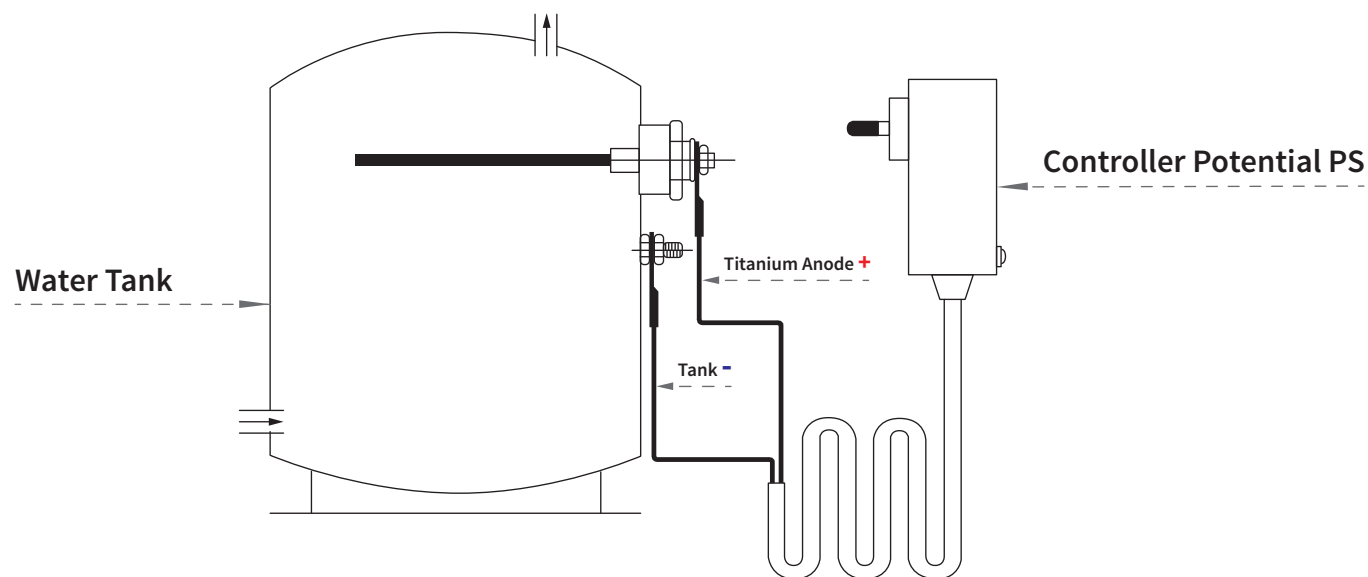

LED SIGNALIZATION	DESCRIPTION
Green color is lit	The controller is operating correctly
Red color is lit	An error has been detected, the controller is not operating correctly



CAUTION

Incorrect wiring can accelerate tank corrosion instead of protecting it!

For better electrical conductivity between the tank housing and the wire end, it is necessary to thoroughly clean the contact surface of the connector, e.g., with fine sandpaper.

## 5.2. TITANIUM ANODE

The titanium anode consists of a plug with a thread of R3/4 inch, a plug seal (O-ring seal), a titanium electrode that is coated with a layer of rare metal oxides at one end and is terminated with an M5 nut thread at the other end, and a silicone sleeve that serves as a seal for the titanium electrode.

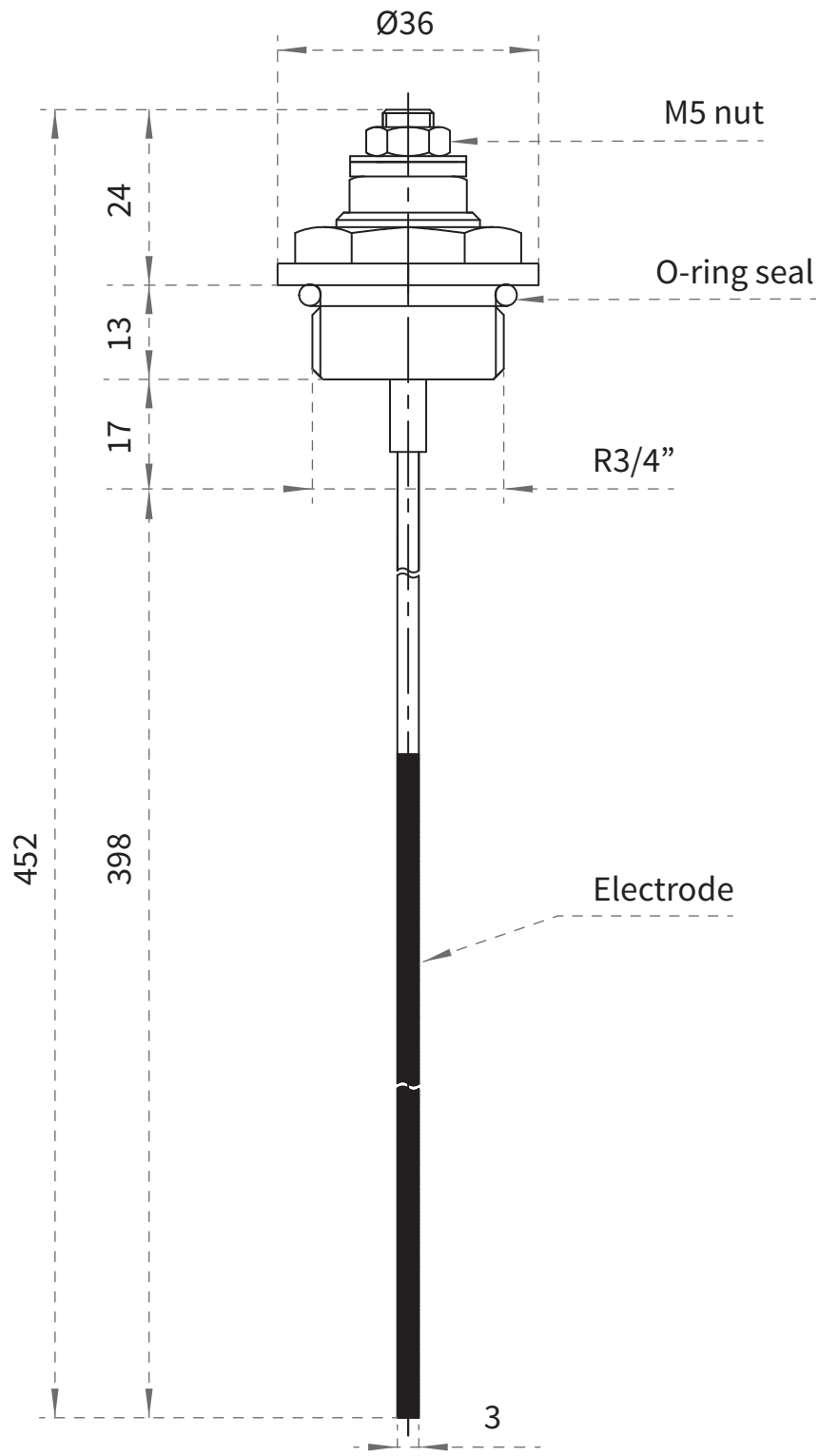

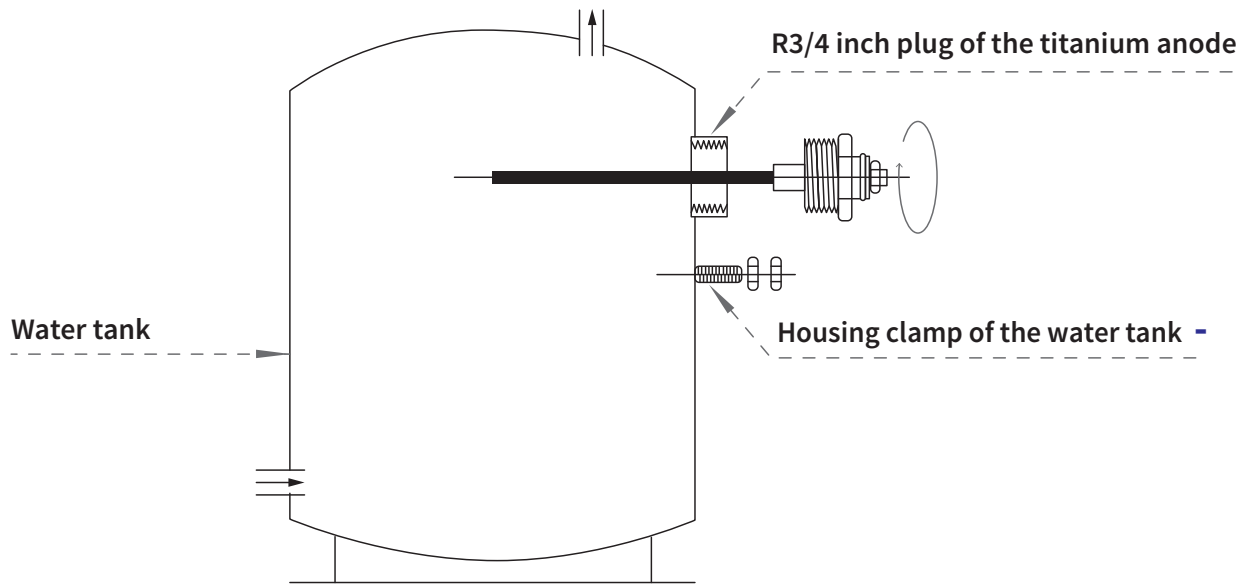

If the hot water tank is equipped with a magnesium anode, it must be removed before installing the titanium anode.

## 6. INSTALLATION OF TITANIUM ANODE AND POTENTIAL CONTROL PS

Before proceeding with the installation, you should:

1. Close the valve on the cold water supply to the tank.
2. Turn off the power to the electric heater in the tank (if applicable).
3. Turn off the power to the heat pump or other device connected to the heating coil (if applicable).
4. Open a hot water tap (e.g., in the bathroom) to relieve pressure in the tank.
5. Open the tank's water drain valve and drain the water into the sewage system.
6. Remove the magnesium anode (if applicable).

**Installation of the titanium anode and potential controller PS:**

1. Screw the R3/4" plug with the titanium anode into the mounting hole of the tank and tighten the plug by pressing the O-ring collar.
2. Ensure that the silicone insulation inside the plug is correctly installed, isolating the titanium anode and preventing any metallic contact with the plug or other tank components (e.g., the coil). Proper insulation of the titanium anode from the tank's surface is essential for the system to function correctly.
3. Connect the controller wires: Connect the wire with the "+" designation to the screw terminal on the titanium anode plug, and connect the wire with the "-" designation to the screw terminal on the tank (as shown in the diagram described in point 5.1).
4. Fill the tank with water.
5. Plug in the power controller to the 230V~ power supply. The LED on the controller will initially light up red and, after a short time, change to green, indicating that the system is operating correctly.

**Possible reasons for the system malfunction - LED glowing red:**

- Pipes bringing in and carrying away cold and hot water, as well as the pipes of the heating coil, are not electrically insulated from the tank.
- The tank is not filled with water, or there are air cushions in the tank.
- The controller wire ends were connected incorrectly (wrong polarity).
- A break in the continuity of the DC circuit of the controller (break in the wire or poor contact at the cable end connection).



## 7. USAGE

---



The installer should inform the user about the functions of the titanium anode and the potential controller PS and provide necessary information for safe usage. Before starting to use, read this manual carefully and follow the instructions it contains.



The use of the titanium anode and potential controller PS should not be entrusted to children or individuals with limited physical, sensory, or mental abilities or to a person without the required experience and knowledge unless they are supervised or instructed on the safe use of the device by a person responsible for their safety. Keep the device out of the reach of children.

### Safety principles for the proper use of the titanium anode and potential controller PS during operation include:

1. If the tank is not in use, do not leave water in it for more than 3 months. This can lead to the accumulation of hydrogen inside the tank. Before this time elapses, open the hot water valves to allow any trapped hydrogen to escape from inside the tank.
2. At least once a month, check whether the green LED indicator light on the controller's housing is lit, indicating that the system is operating correctly.
3. Do not turn off the power to the controller when the tank is filled with water. Turning off the controller is necessary when you want to drain the water from the tank.



Failure to comply with the above information will result in the loss of warranty. In case of any irregularities, please report this to an Authorized Service Partner or the manufacturer's service department.

## 8. INSPECTION

---

At least once a month, you should conduct a visual inspection of the condition of the titanium anode and potential controller PS, including checking the connections for leaks and verifying the proper functioning of the system. The inspection of the titanium anode and potential controller PS should be performed every 36 months.

## 9. DISPOSAL

---

To dispose of the used device, follow these steps:

1. Disconnect the device from the 230V~ power supply.
2. Drain the water from the tank into the sewer system.
3. Disassemble the device.
4. Dispose of all plastic elements in accordance with recycling guidelines.
5. Dispose of the potential controller PS.
6. Recycle clean metal elements.

## 10. SERVICE

---



Improper repair or incorrectly conducted servicing of the device may damage the device and/or cause bodily harm.

To ensure the best quality and safety, all repairs and servicing of the device should be carried out by an Authorized Service Partner of the manufacturer, who will determine the scope and method of repair in agreement with the manufacturer.

## NOTES

A series of horizontal dotted lines for taking notes.

## NOTES

A series of horizontal dotted lines for writing notes.

MANUFACTURER'S STAMP

**HOME STAR Sp. z o.o.**  
ul. Misjonarzy Oblatów 20A  
40-129 Katowice  
KRS 0000729842 NIP 634 292 88 43



**THERMATEC | Home Star sp. z o.o.**  
Misjonarzy Oblatów MN 20A  
40-129 Katowice, Polska [Poland]

Office: (+48) 32 722 02 03  
Mobile Phone: (+48) 533 222 223  
biuro@thermatec.pl

[www.thermatec.eu](http://www.thermatec.eu) | [www.thermatec.pl](http://www.thermatec.pl) | [www.thermatec.cz](http://www.thermatec.cz) | [www.thermatec.fi](http://www.thermatec.fi) | [www.thermatec.nl](http://www.thermatec.nl)

**TH-Ti800**

TH-AT-INS-2023-08-1